

US-P1

User Manual

Operating voltage: 8-32VDC

Signal Input: 4-20mA



Index

Page No

• Technical parameters	02
• Terminal definition/ Typical wiring	02
• Alarm Information	02
• Parameter setting	03
• Parameter list	03

www.hydrootvet.ru

Technical parameters

Operating voltage	8-32 VDC
Signal input	0-5V, 0-10V, 4-20mA
Output current	0-3 A
Dither frequency	50-450Hz
Opposite time	0-99.9 S
Reference voltage	5V
Protection level	IP65
Operating temperature	-40 to 70°C
Storage temperature	-40 to 85°C

Terminal definition/ Typical wiring

Sub number	Terminal Name	Meaning
1	+UB	power supply
2	0V/CMD-	Power-/Command-
3	CMD+	Intruccion+
4	VREF_5V	Reference voltage 5V
5	ENA	Enable (high)

Notice:

On the factory state, the external enable function is prohibited (no need to connect No. 5 ENA terminal). If the user needs to enable the function, you need to set the value of parameter R to 1.

Typical wiring 1: Input Instructions through PLC and industrial computer

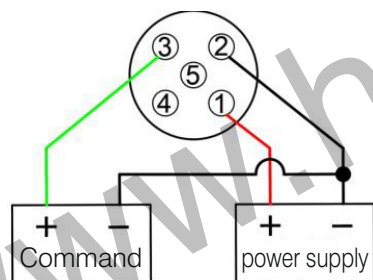

Typical wiring 2: Input command through potentiometer.

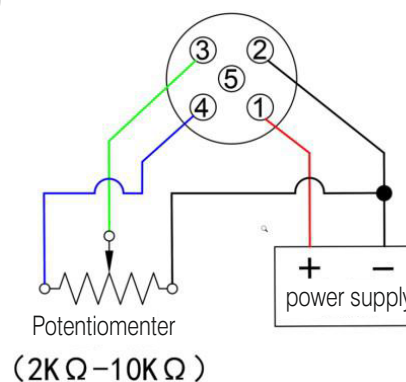

Alarm Information

Digital tube alarm	Failure description	Fault removal
E 10	4-20mA input disconnection	After troubleshooting the fault information is automatically cleared.
E 11	4-20mA input overload	After troubleshooting the fault information is automatically cleared.
E 30	The solenoid wire calendar is broken	After troubleshooting the fault information is automatically cleared.
E 31	Short circuit of solenoid coil	After trouble shooting you need to re-power on or enter the parameter. The T-meter performs the southern fault removal operation (PeL) to clear the fault Barrier information.
E 80	Parameter storage failed	Clear the fault by restoring the factory parameters (P-F)

Parameter Setting

Parameter Setting Steps

- In the default interface (display the current or command), press and hold the SET key to enter. Enter the parameter list Interface. (Long press the SET key again to return to the default interface)
- Use or ▼ to switch to find the parameter name that needs to be set.
- Press the SET key to enter the parameter value display interface.
- Use ▲ or ▼ to adjust the parameter value.
- Press the SET key to return to the parameter list interface.
- Enter the parameter PSR (parameter save), adjust the parameters until the parameter. Value 5, save the parameters successfully. return to the default interface.

Bottom meaning

▲ = Up turn

▼ = Flip down

Set = Confirm

Notice:

After adjusting the parameter, the parameter value will take effect immediately, but if there is no setting to save the setting in step 6 above, refer to the value cannot be saved after power-off

Parameter List

Digital tube	Parameter Name	Factory default	Scope	Unit	Illustrate
P _H	Maximum current	0.80	0.20-3.00	A	Adjustment step: 0.01A
P _L	Minimum current	0.20	0.00-1.00	A	Adjustment step: 0.01A
P _{rU}	ramp up time	0.0	0.0-99.9	S	Adjustment step: 0.15
P _{rD}	ramp down time	0.0	0.0-99.9	S	Adjustment step: 0.15
P _{A I}	input signal	10	5 10 420	-	5: 0-5V 10: 0-10V 420: 4-20mA
P _{dF}	Along frequency	150	50-450	Hz	Adjustment step: 5Hz
P _{cD}	Command dead zone	2	0-5	%	Adjustment step: 1%
P _{dS}	Display type	0	0 1	-	0: Output current 1: Input command (V/mA)
P _{SA}	parameter save	0	0-5	-	When the value is greater than 5, save the parameter
P _{rF}	Restore factory parameters	0	0-5	-	When the value is greater than 5, Restore the factory parameter
P _{cL}	fault clearing	0	0-5	-	When the value is greater than 5, clear the overcurrent fault code

Note:

- The setting of the baud rate bd will not take effect immediately, it needs to be saved through the parameter PSR, and after the power is turned on again It can take effect.
- Parameters PSR, P-F, PrL (save parameters, restore factory parameters, fault clearing) setting method:
Enter the parameter value interface, press the A key until the displayed value is greater than 5, the setting is successful and automatically jump back to the default interface noodle.